

Gateroad Development in Thick Seams Using the Joy Sump Shearer

B Ward¹ and M Downs²

ABSTRACT

The use of a cutting machine designed to allow simultaneous cutting and setting of roof supports has numerous advantages few development roads in coalmines. The use of such a machine with the added ability to cut a curved roof profile is of considerable interest for longwall development in thick coal.

INTRODUCTION

Gateroad development in Australia has evolved in the direction of integrated activity around cutting and bolting machines, in line with the thinking that gateroads were essentially service tunnels for the longwall. This has led to the focus on the single pass continuous miner (CM) fitted with integral bolting rigs.

Several new generation machines have been designed to progress this line of thinking by sumping in the cutting head to permit simultaneous roof bolting and cutting. One of these new machines is the Joy Sump Shearer (JSS). It differs from a CM in having the cutting heads on ranging arms like a longwall shearer, which can allow it to cut a variable heading profile.

This paper presents a case for using the JSS for gateroad development in thick seams in weak strata, whereby a curved roof profile can be formed to improve stability. A spiral arch roof support configuration is designed to improve the efficiency of the cutting/bolting cycle, which together with an integrated coal clearance system using a mobile boot end, should permit faster, safer gateroad development.

ARCHED ROOF PROFILE

Historically, heading development has been carried out by a continuous miner, which is designed essentially as a high volume coal cutting machine. With a cutting head rotating about an axis parallel to the face with vertical ranging, a CM can only form a rectangular heading section. This has obvious advantages in coal mining where coal seams are tabular bodies bounded by stone roof and stone floor. However, a rectangular section is inherently less stable than a curved, or arched roof section, particularly in a high stress environment where mining induced stresses are concentrated around the corners.

An example of smoothing out the stress trajectories around curved rib profiles was demonstrated by the Dosco In Seam Miner at Ellalong Colliery (Wallman, 1982). The semicircular rib profile provided a spectacular case of improved gateroad stability, unfortunately, the system did not achieve adequate advance rates.

Another example was at Western Collieries in the Collie Basin. AM75 roadheaders with mobile boot ends were used to drive the main headings in a thick seam environment with a CM for pillar extraction. The roadheader normally cut a rectangular profile but an arch profile was used when traversing the intermittent high stress zones, which would otherwise have proved extremely difficult to mine through due to roof instability (Misich, 1993).

¹ Geotechnical Consulting Services Pty Ltd

² BHP Australia Coal

It is a general rule in geotechnical design that the greatest benefit in stability is always gained through geometric change. That is, it is always better to flow with the stress than to try and resist it through increased support. An arched roof is inherently more stable than a flat roof and thus will require less support than a flat roof in the same conditions. Less support means a potential for increased rate of drivage.

The JSS, because of its cutting head configuration, can be programmed to cut a range of curved roof profiles, from a flat rectangular section to a full arch, and hence, unlike the CM, can provide the opportunity to utilise the advantages of heading profile geometry.

Cutting stone roof to achieve an arched profile is obviously most unattractive in all but extreme circumstances. For the majority of Australian longwall mines, operating in a seam thickness from 2.2m to 2.8m, arched rooves are not an option. In a thick seam operation, however, this is no longer a constraint.

The northern part of the Bowen Basin coalfield in Queensland is characterised by seams with thicknesses in excess of 4m. Of particular interest in the context of this paper is the Goonyalla Middle Seam (GM), which is typically around 5.0m to 5.5m thick in current and prospective underground mining areas. In a seam of this thickness it is possible to have in seam development with a curved roof profile, with adequate dimension to meet ventilation requirements and without incurring unwanted dilution from stone roof.

JOY SUMP SHEARER

The JSS represents an innovative and radical approach to underground heading development. It has been designed as a single pass machine configured to allow simultaneous cutting and bolting. It differs from a conventional CM design in having the coal cutting function performed by twin 1.1m diameter cutter drums on ranging arms, rotating about axes perpendicular to the face, in a similar fashion to a longwall shearer. Coal clearance is via an east-west face conveyor, transferring to a through the body conveyor to the tail discharge.

The frontal aspect of JSS is shown in Fig.

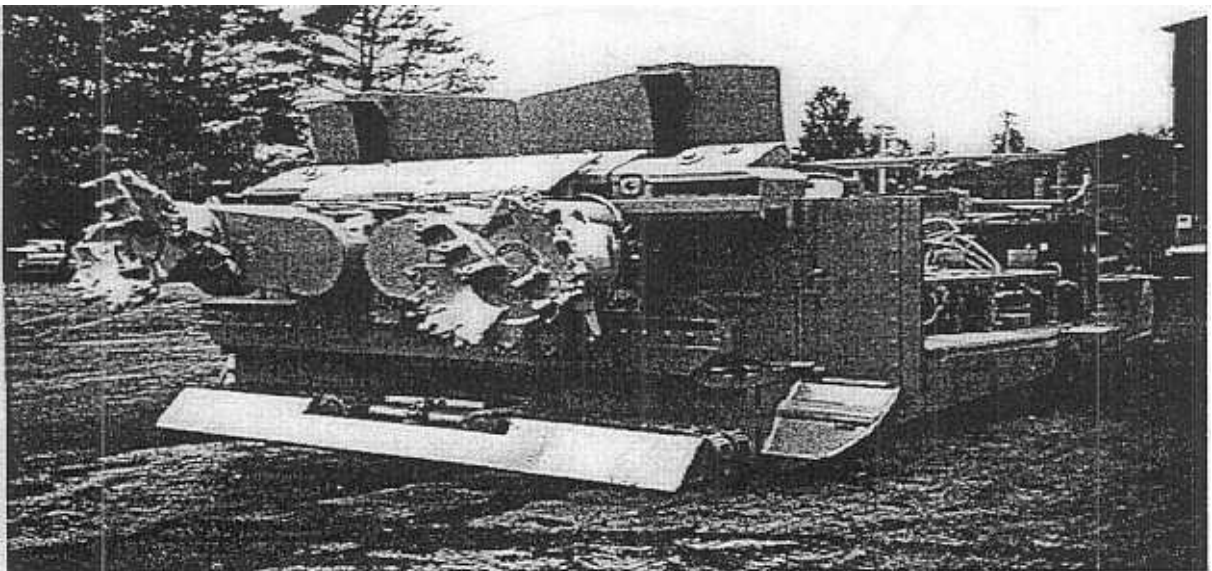

Fig. 1 - Frontal aspect of JSS

The coal cutting equipment is separated from the working platform behind it by a face shield and side doors, which enclose the front of the JSS to allow any build up of gas or dust to be exhausted through the body of the machine into the mine ventilation system. This enables the operatives to install support whilst the machine is cutting coal.

The JSS is programmed for automatic sumping and profiling, the operator typically changing only mining height and floor options to match geological conditions. The cutter heads are sumped in (0.5m sump depth) by driving the machine forward, after which they cut the programmed heading profile. Bolts are installed during the profile cut. Roof support consumables are carried in pods on the machine with mechanised loading at cut-throughs for re-supply.

Roof support is installed by twin on board drills mounted immediately behind the shield. The configuration is such that bolts are placed approximately 1.5m from the face.

ROOF SUPPORT

Roof support design for gateroads should be aimed at providing the minimum amount needed in the short term to advance the heading, without prejudice to safety, such that any additional or secondary support can be placed later without slowing development rates. In addition the system must be sufficiently flexible to allow for variation or additional support to match any changes in ground conditions, such as when penetrating faults or zones of structural disturbance.

The proposed design for the JSS is based on cutting a partial arch in a 5.0m wide heading. Fig. 2 shows the general configuration. The arch has a 3.4m radius giving a maximum height of 3.3m

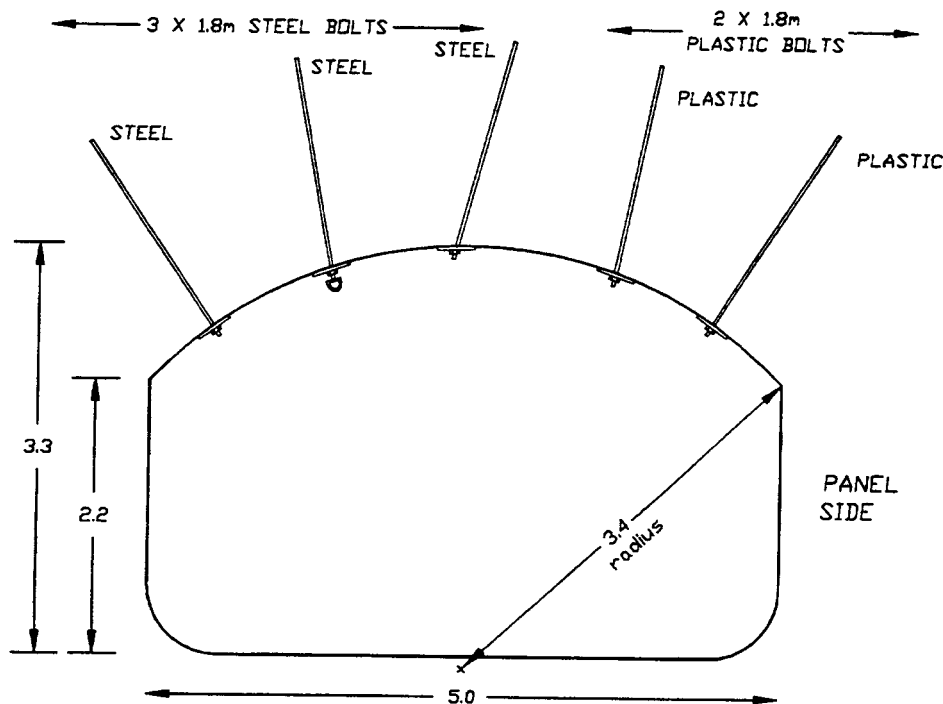

Fig. 2 - Heading profile and roof support

with 2.2m high ribs. The cross sectional area is 15.2 m^2 , equivalent to a conventional rectangular heading 5.2m wide by 2.9m high. Ideally a fuller arch is desirable (3.0m radius) but this would entail considerable re-engineering and is not possible with the currently available JSS. The proposed design is thus the best compromise that is practically achievable.

The arch is reinforced with a basic spiral arch pattern of 5 x 1.8m roofbolts arranged radially, or as near radial as possible with the twin bolting rigs. The three bolts on the pillar side are conventional T grade steel, the two on the panel side are plastic (i.e. cuttable) for reasons discussed later. The bolting arrangement is reversed in the tailgate.

Bolt spacing along the gateroad is linked to the 0.5m sump depth for the basic pattern, which gives a longitudinal bolt spacing of 2.0m (four sumps). The bolting pattern is thus equivalent to 5 bolts per 2.0m spacing but the pattern is arranged as a spiral arch rather than transversely in line. Fig. 3 shows the basic spiral arch pattern. Bolts are installed at 0.5m centres on the advance whilst the computer controlled profile is being cut. As bolt installation is linked to the sumping it will ensure a uniform spacing and density is achieved.

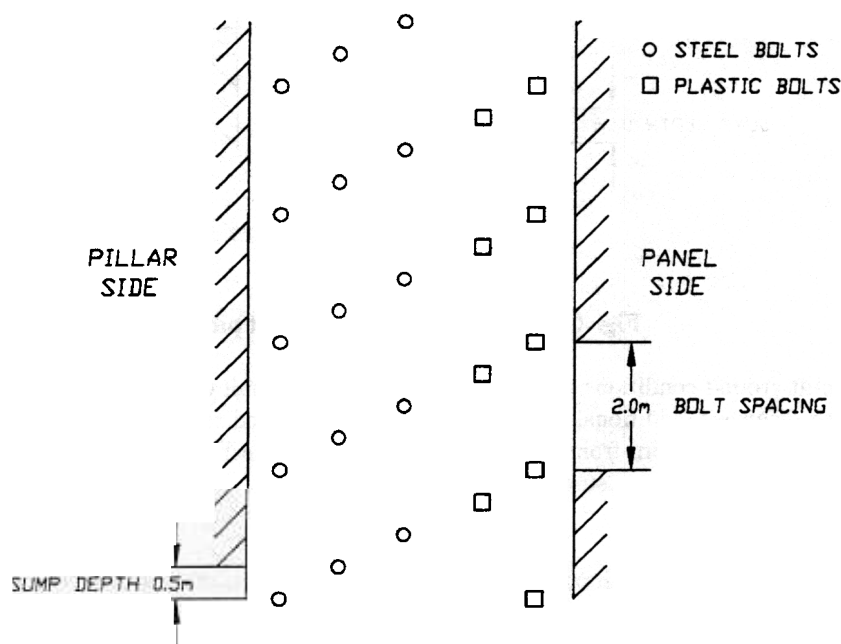

Fig. 3 - Spiral arch roof support pattern

Two on board bolting rigs are required for the sequence. The two outer bolts are installed simultaneously with the other three installed at the rate of one per sump. By this means machine advance and coal cutting will not be compromised by the bolting sequence. The two bolt types are segregated such that only steel bolts are placed by the bolting rig on the pillar side whilst only plastic bolts are installed by the other rig.

The system is flexible enough to allow the support density to be increased without interfering with the cycle. Fig. 4 shows the next level of support, a herring bone pattern, whereby bolts are installed at 1.5m spacing. In this case two pairs are installed simultaneously but again, only one bolt per rig is installed in any cutting cycle.

Primary rib support is not envisaged as being necessary as the partial arch shape keeps rib height to 2.2m in contrast to current heights of 3.0m plus with rectangular sections.

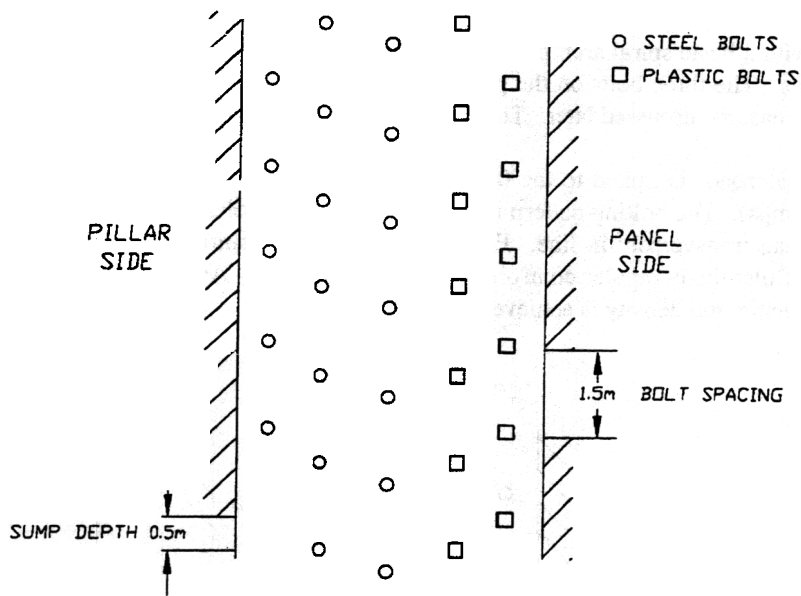

Fig. 4 - Herring bone roof support pattern

In the event that difficult ground conditions are encountered, such as in fault or shear zones where the roof strata may be more closely jointed or disturbed, additional primary support can be placed radially at each sump. The configuration of the JSS enables bolts to be placed 1.5m from the face. Cutable plastic mesh panels can be installed in extreme cases, or where roof stability would be at risk from subsequent abutment loads.

Another major potential benefit of the arch profile is that any subsequent abutment stresses during extraction will be more evenly distributed around the roof and into the ribs. This could reduce the need for additional passive support such as cribs. Secondary support, if needed, is envisaged as 2 x 6m resin-grouted tendons at 2.0m or 2.5m centres. These would be installed subsequently by outbye crews or contractors with mobile equipment. A single timber or fibre crib would be placed across each cut-through as per normal practice to restrict intersection span, prior to extraction.

DEVELOPMENT SYSTEM

Mining system

The system proposed for gateroad development comprises two JSS driving each entry simultaneously. The section conveyor has a mobile with the JSS driving the conveyor heading discharging coal onto the section conveyor via a belt bridge. The travelling road and most of the cut-through would be driven by the second JSS, operating with a ram car/battery hauler loading coal onto the section conveyor via a side loading belt.

Both JSS would be supported by inbye mono-rail mounted services, each mono-rail system being independent and of similar format. The inbye mono-rails would be in turn supported by an outbye mono-rail system, this being designed to facilitate the easy advancement of major section services.

The intensive use of mono-rail systems eliminates much of the repetitive down-time associated with advancing services as mining progresses. Significant benefits accrue from mechanising such functions, including enhanced safety due to much reduced handling of sundry pieces of equipment, the elimination of production delays normally associated with moving services forward, possible face labour reductions and greater speed of cyclic section advances.

The outbye mono-rail system also mechanises a previously labour intensive and time consuming activity by enabling easy and rapid advancement of the section transformer. Again, general safety is greatly improved by the elimination of the significant and usually manually completed task of advancing the feeder cables.

Equipment

The general arrangement of the face area equipment and the inbye mono-rail system is shown in Fig. 5.

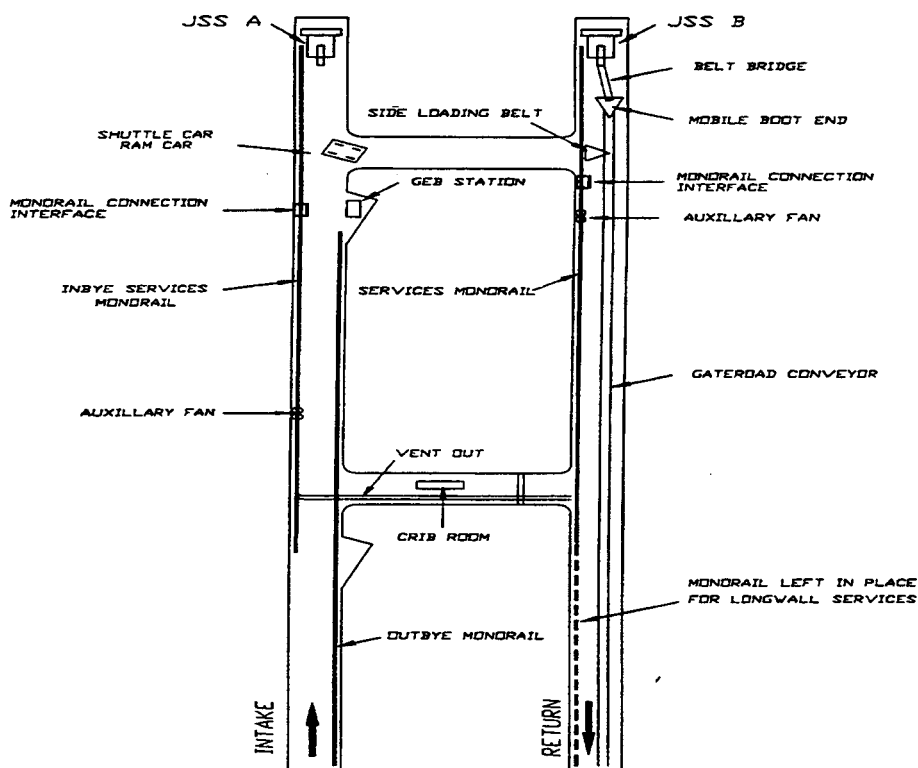

Fig. 5 - Schematic arrangement of face area equipment

JSS 'A' would drive the travelling road supported by a ram car or battery hauler. Coal clearance would be via a side loading belt in the cut-through. This side loading belt would be a readily demountable unit, with wheeled telescopic legs at the discharge end and retracting wheels at the loading end. When in operation, the loading end would be lowered to the floor and held in position by dowels and turnbuckles.

JSS 'B' in the conveyor road heading would discharge coal via a belt bridge which would be attached to the end of the JSS conveyor boom by a swivelling joint with a sliding section over a mobile boot-end. The use of the belt bridge enables a continuous coal throughput to be achieved whilst allowing the ability for the miner to pull back from the face - either to clean up or for maintenance - and also to partially form the cut-through.

Services (ventilation, power, water and compressed air) would be provided by the inbye mono-rails. Both mono-rails would also be of similar format, with a combination of flexible ducting and rigid sections as dictated by the specific requirements of the installations.

The mono-rail track in the conveyor road would form the basis for the longwall mono-rail system, consequently being erected on the pillar side of the roadway and left in position as the section advances. This monorail would be suspended from the middle steel roof bolt on the pillar side.

The mono-rail system in the travelling roadway would be erected on the panel side of the road, so as to avoid impacting on shuttle car load clearances at the cut-through, and salvaged as the section advances inbye for re-use at the working face. This temporary suspension would be on the plastic bolts.

The inbye mono-rails would be in turn supported by an outbye mono-rail system in the travelling road, accommodating services from the section transformer location/end of pipe range area, to the outbye end of the face mono-rails. The outbye mono-rail system and equipment is shown schematically in Fig. 6.

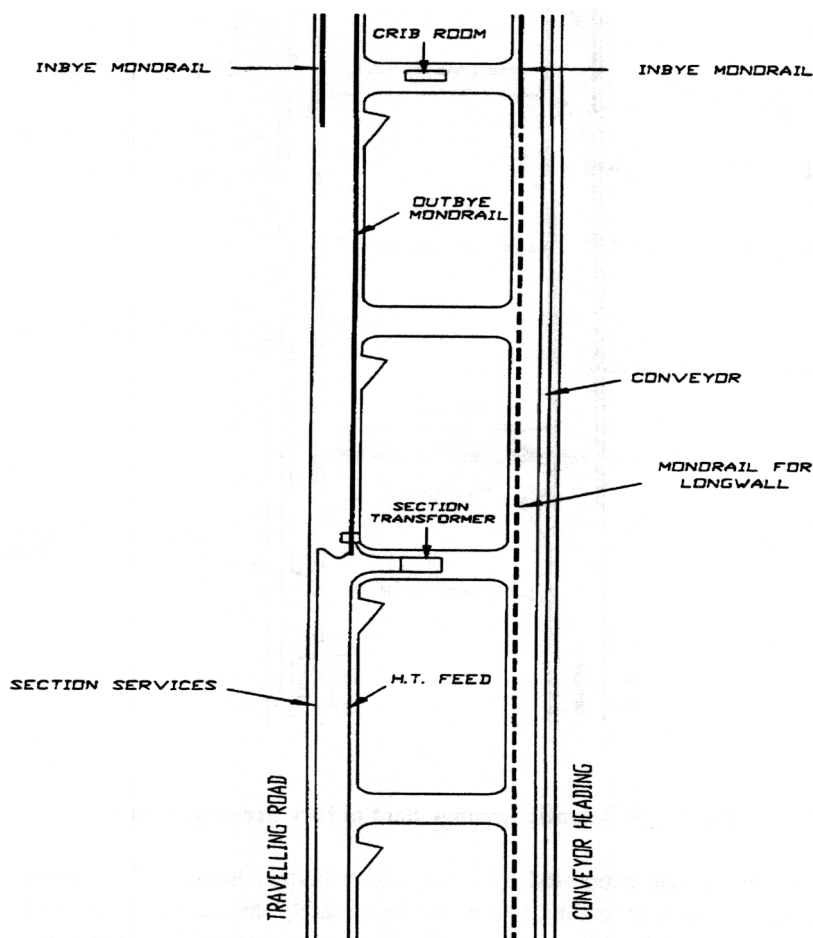

Fig. 6 - Schematic arrangement of outbye section equipment

The outbye mono-rail would be suspended from the pillar side steel roof bolts and would supply the following:

- power in the form of feeder cables from the section transformer to the load centre(s);
- water, through large diameter hoses to supply face dust suppression requirements as well as high volumes required for fire hydrants mounted on certain of the carriages;
- compressed air for both the mono-rail system "mule" drives and for general use; and
- sundry monitoring and communication cabling.

Drivage sequence

The section drivage sequence is shown by Fig. 7, which also broadly defines the split in requirements between the two JSS development machines. JSS 'B', with its attendant belt bridge, is required to form approximately 5m of the cut-through so that JSS 'A', which cuts the remainder of the cut-through, does not have to hole through in an area that would compromise equipment in the roadway, such as the mono-rail and the conveyor.

The inbye mono-rail system advances with each of the JSS, automatically bringing forward ventilation and power and water services. At the end of the designated drivage, the outbye end of each of the face mono-rails is moved forward and causes the flexible sections to compress as they are bunched up against the rigid, inbye ends. In this way, there is no manual handling of face cables, hoses, or ventilation tubes.

The outbye system also removes two activities off the critical path for a section advance, these being the extension of the pipe ranges and the extension of the H.T. cable. Both of these functions can be completed at any time over at least two complete cycles (i.e. two pillar lengths of section advance), without any delay to the production at either face.

Productivity

A cross-sectional area of 15.2 m² and a web depth of 0.5m will produce approximately 10.6t per sump cycle, that is one load for the coal hauler. A cutting and loading capacity of 10 tpm is assumed for the JSS.

An approximation of the productivity of JSS 'A' has been approached by considering the likely working times in a median position in the overall cutting cycle. It is assumed that a point 90m up the travelling road from the loading cut-through is representative of an average face position for this machine. Roof-bolting time per bolt is assumed to be 2 minutes.

For JSS 'A' the major component in the cutting cycle is the travel time of the coal hauler. Analysis indicates a production rate of some 120 tph, giving an output of about 780 t/shift, equivalent to a face advance of 39 m/shift, for an effective face time of 6.5 hours. Discounting performance to reflect operating efficiencies and system reliability by a factor of 0.75, indicates that the expected shift advance of JSS 'A' would be 30m (producing about 600t ROM).

The duty cycle for JSS 'A' only involves coal cutting, roof support and coal clearance functions. Hence the face crew can be limited to 4 persons.

JSS 'B' employs a belt bridge that should virtually eliminate coal clearance delays. Some loss of production time will occur when the machine is pulled back to clean up the roadway and possibly to enable a correction to be made to the recently installed conveyor structure but these are assumed to be included in the general discount factor for the purposes of this paper.

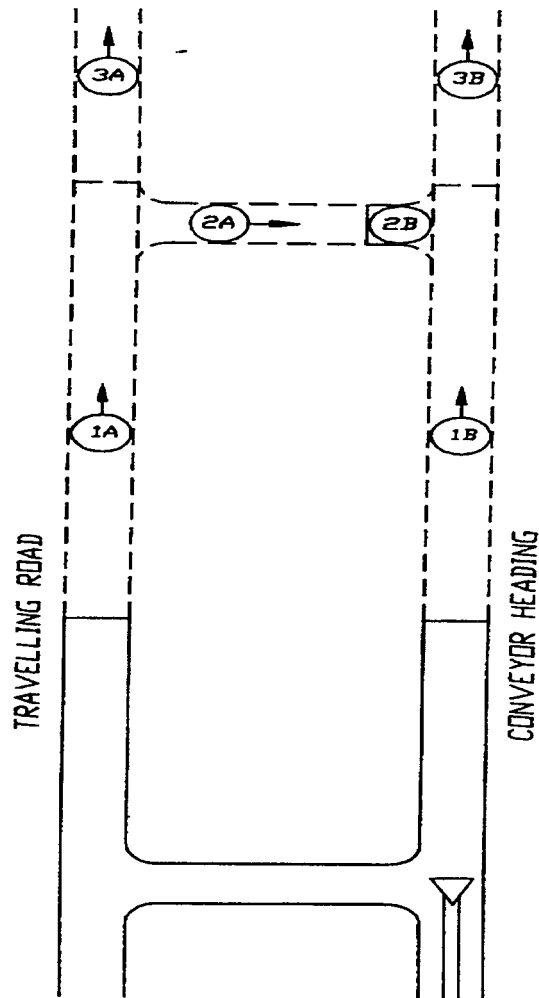

Fig. 7 - Drivage sequence plan

The only functions to be considered for JSS 'B' are cutting, loading and roof support. The roof support cycle of 2 minutes realistic minimum bolting time exceeds the nominal cutting and loading time of 1 minute, as no bolting is considered possible during the machine sumping function. The sumping action is presumed to take 1 minute. The total cycle for this face is therefore 3 minutes for an output of 10.6t.

For an effective face time of 6.5 hours, this would produce an output of 1300t ROM, is equivalent to a shift advance of 65m. Again, applying a discount factor of 0.75 to reflect operating efficiencies and system reliability, the expected performance of JSS 'B' would be a face advance of 48m per shift, producing an output of 975t.

This rate of face advance will require a conveyor extension of approximately 11 bays of structure. Minimal effort would be required to advance the general face services due to the mono-rail facility.

The installation of 11 bays of structure is considered a relatively easy task to achieve in a shift and would require an intermittent maximum of 4 persons to complete.

The indicative manning for JSS 'B' would be 3 operators (including supervisor), 1 tradesman (probably electrical allowing for mechanical training of operator) plus 2 persons for backbye support. This gives a total complement of 6.

Backbye work in what is essentially a "super section" will comprise the need for rapid services extensions and general section support work. It is estimated that these functions would require an outbye crew of 4 multi-skilled operators to keep pace with the face advance. Therefore, the overall manning level for the mining system outlined would be 14 per shift.

Critical path analysis indicates that the overall section cycle is likely to be of the order of 8 shifts - assuming that the key parameters of advance rates and support work duration are met.

The rate of section advance implied by the cycle time is approximately 2 x 100m pillars advance per week. This is equivalent to some 920m per machine per month, which is close to current industry best performance in simple terms, but which when included in the system described results in an excellent rate of section linear advance.

INTEGRATION WITH LONGWALL

One issue with thick seam longwall extraction is managing the disparity between longwall mining height and the gateroad height. Gateroads are normally restricted to a maximum of 3.5m high, which will leave a differential of up to possibly 1.5m compared to the extraction height. High gateroads are not desirable from a geotechnical point as they increase the potential for roof and rib instability. In addition they require specialised lifting equipment for operators installing secondary support and create onerous conditions for erecting crib support with attendant risk of injury.

The general solution to date has been to ramp the longwall face either down to match the roof line or up to match the floor line, depending on whether coal has been left on the floor for trafficking in the gateroads. Whichever way, managing the ramping involves constraints or controls on the longwall operation (delays to shearing cycle) and also some loss of coal that could otherwise be mined.

The provision of cuttable bolts on the panel side of the gateroad roof is designed to permit the shearer cutting height to be maintained into the gateroads without change of horizon. By this means the complication and inefficiency of roof ramping will be avoided whilst still retaining the desired stability of a moderate gateroad height.

Fig. 8 shows the maingate configuration. Development is at or close to floor level as trafficking is not such an issue with the mobile boot end. A coal floor thickness of 0.5m has been allowed in the design as a degree of conservatism with regard to the weak floor associated with GM Seam. The floor is thus ramped up to meet this. At roof level the shearer cuts in over the panel side of the gateroad through the cuttable bolts without changing horizon.

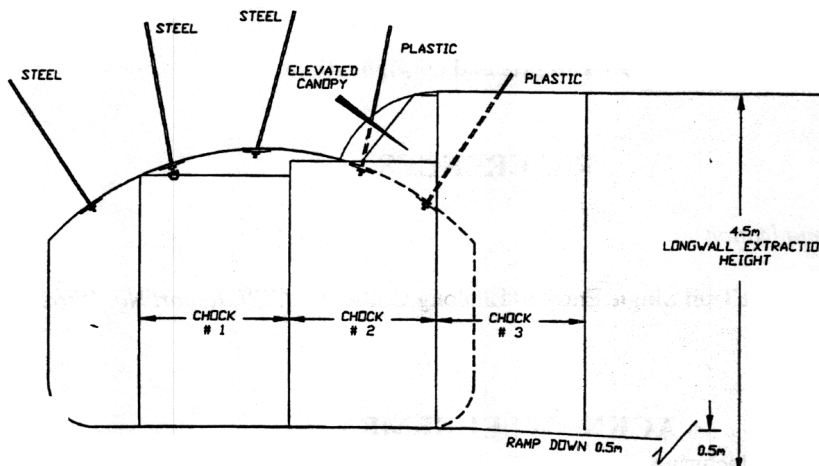

Fig. 8 - Maingate end configuration

The main complication is in setting the maingate chocks against the roof. With 1.75m chock shields there will be two chocks in the maingate, both of which are set against the curved roof section at a lower height. Chock #2 will have to set

against the remnant coal roof fillet in the crown. As the goaf break line is inbye of the gatend, these chocks are not needed to control goafing, their primary purpose being to advance the stage loader and protect against falls of loose rock. A reduced setting pressure can thus be applied to these chocks to enable Chock #2 to be set safely against the roof fillet.

Chock #2 will be provided with a part elevated canopy top to match the roof geometry, depending on the final longwall/chock design configuration, to prevent any breakage from the coal fillet from flushing sideways beneath its canopy. Any downdip face creep will automatically be accommodated in the design as the roof cut will always be in the same place relative to the chocks out by taking the shearer to the same finishing point on the AFC. Racking potential will also be reduced with lower height maingate chocks.

Fig. 9 shows the tailgate configuration. Approximately 0.8m of coal is left in the floor as a trafficking surface for the coal haulers. The shearer cuts into the floor, as per current practice in the Bowen Basin, and cuts into the roof as per the maingate, thus permitting full extraction height to be maintained. Only one chock is present in part in the tailgate so that special chock design modifications are not needed.

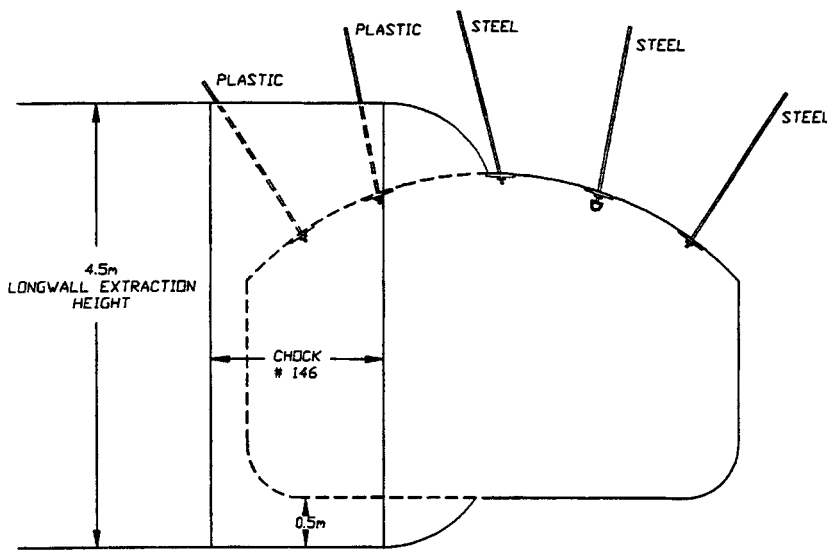

Fig. 9 - Tailgate end configuration

REFERENCES

Misich I, 1993. *Personal Communication*

Wallman D, 1982. Results of the First Trail Single Entry at Ellalong Colliery, *ACIRL Report No. PR82.1*

ACKNOWLEDGEMENTS

The authors wish to thank Joy Manufacturing Company Pty Ltd for their support and cooperation in regard to the use of the Joy Sump Shearer. The concepts and opinions expressed in this paper are those of the authors and do not necessarily coincide with the views of BHP Australia Coal.